



**Cambridge International Examinations**  
Cambridge International General Certificate of Secondary Education

**CHEMISTRY**

**0620/12**

Paper 1 Multiple Choice (Core)

**February/March 2017**

**45 minutes**

Additional Materials:      Multiple Choice Answer Sheet  
   Soft clean eraser  
   Soft pencil (type B or HB is recommended)

\* 7 5 0 6 9 8 0 5 6 8 \*

**READ THESE INSTRUCTIONS FIRST**

Write in soft pencil.  
Do not use staples, paper clips, glue or correction fluid.  
Write your name, Centre number and candidate number on the Answer Sheet in the spaces provided unless this has been done for you.  
**DO NOT WRITE IN ANY BARCODES.**

There are **forty** questions on this paper. Answer **all** questions. For each question there are four possible answers **A, B, C** and **D**.  
Choose the **one** you consider correct and record your choice in **soft pencil** on the separate Answer Sheet.

**Read the instructions on the Answer Sheet very carefully.**

Each correct answer will score one mark. A mark will not be deducted for a wrong answer.  
Any rough working should be done in this booklet.  
A copy of the Periodic Table is printed on page 16.  
Electronic calculators may be used.

The syllabus is approved for use in England, Wales and Northern Ireland as a Cambridge International Level 1/Level 2 Certificate.

This document consists of **16** printed pages.

- 1 A bottle of aqueous ammonia is placed on a table in a corner of the laboratory.

The stopper is removed and after a few minutes all the students in the room can smell the ammonia.

Which process occurs?

- A Brownian motion
  - B diffusion
  - C dissolving
  - D distillation
- 2 A student is investigating a coloured mixture using chromatography.

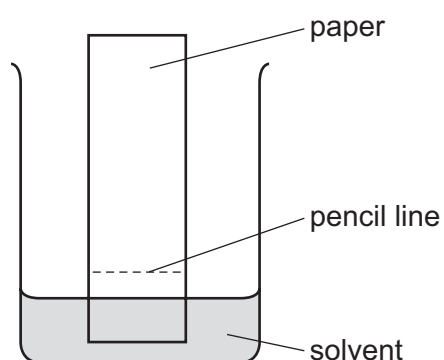

Where should the student place the coloured mixture?

- A in the solvent
- B just above the pencil line
- C just below the pencil line
- D on the pencil line

3 The diagrams show liquids in a burette and a measuring cylinder.

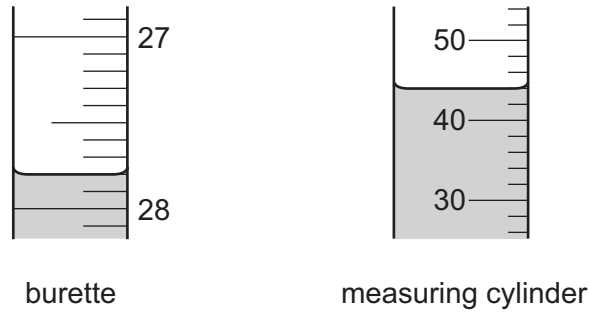

Which row shows the correct readings for the burette and the measuring cylinder?

	burette	measuring cylinder
<b>A</b>	27.8	42
<b>B</b>	27.8	44
<b>C</b>	28.2	42
<b>D</b>	28.2	44

4 The diagram shows how muddy water can be purified.

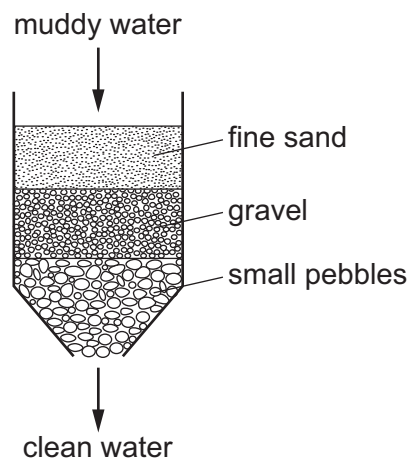

Which process for purifying the muddy water is shown?

- A** crystallisation
- B** distillation
- C** filtration
- D** solvent extraction

5 The aluminium ion,  $Al^{3+}$ , has the same electronic structure as an atom of which noble gas?

- A argon
- B helium
- C krypton
- D neon

6 A covalent molecule M contains a total of four shared electrons.

What is M?

- A ammonia,  $NH_3$
- B hydrogen chloride,  $HCl$
- C methane,  $CH_4$
- D water,  $H_2O$

7 Three substances have the properties shown.

- X conducts electricity when solid and when molten.
- Y is soluble in water and the solution conducts electricity.
- Z only conducts electricity when molten.

What are X, Y and Z?

	X	Y	Z
A	Ca	MgO	NaOH
B	Ca	NaOH	MgO
C	MgO	Ca	NaOH
D	MgO	NaOH	Ca

- 8 Caffeine is a stimulant found in coffee.

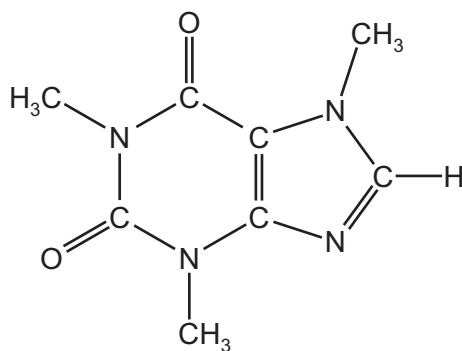

caffeine

Which formula represents caffeine?

- A**  $C_7H_{10}N_4O_2$     **B**  $C_8H_{10}N_3O_2$     **C**  $C_8H_{10}N_4O_2$     **D**  $C_8H_{11}N_4O_2$

- 9 Four substances are electrolysed.

The substances are concentrated aqueous sodium chloride, concentrated hydrochloric acid, molten lead(II) bromide and molten sodium oxide.

Which statement about these electrolysis reactions is correct?

- A** A colourless gas is formed at the anode when molten sodium oxide is electrolysed.  
**B** A green gas is formed at the cathode when concentrated hydrochloric acid is electrolysed.  
**C** A metal is formed at the anode when molten lead(II) bromide is electrolysed.  
**D** A metal is formed at the cathode when concentrated aqueous sodium chloride is electrolysed.
- 10 Ammonium chloride is added to  $100\text{ cm}^3$  of water. The temperature changes from  $25^\circ\text{C}$  to  $20^\circ\text{C}$ .

Which type of reaction occurs?

- A** endothermic  
**B** exothermic  
**C** freezing  
**D** neutralisation

11 A diagram for the energy change during an exothermic reaction is shown.

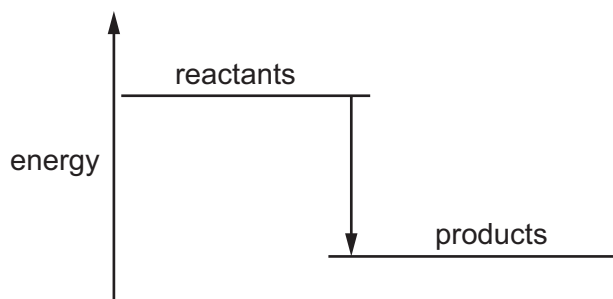

For which reactions would this be an appropriate diagram?

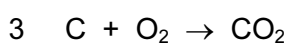
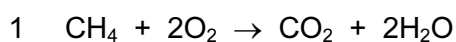

- A none of them
- B 1 and 2 only
- C 2 and 3 only
- D all of them

12 The diagram shows the apparatus used to measure the rate of a chemical reaction.

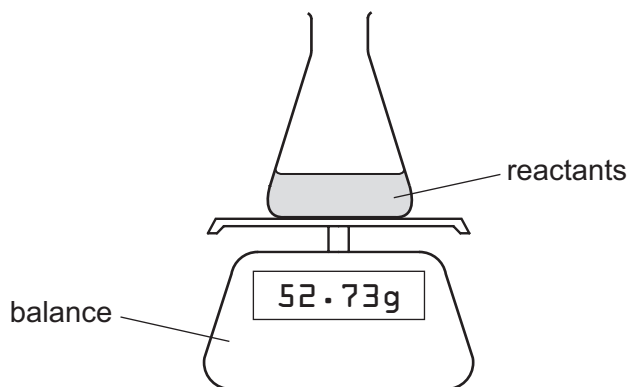

For which reaction can the rate be measured using this apparatus?

- A  $2\text{Na} + \text{Cl}_2 \rightarrow 2\text{NaCl}$
- B  $\text{NaOH} + \text{HCl} \rightarrow \text{NaCl} + \text{H}_2\text{O}$
- C  $\text{Na}_2\text{O} + 2\text{HCl} \rightarrow 2\text{NaCl} + \text{H}_2\text{O}$
- D  $\text{Na}_2\text{CO}_3 + 2\text{HCl} \rightarrow 2\text{NaCl} + \text{H}_2\text{O} + \text{CO}_2$

13 Copper(II) carbonate reacts with dilute sulfuric acid.

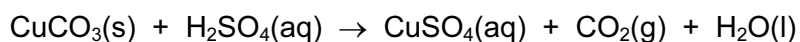

The rate of the reaction can be changed by varying the conditions.

Which changes always increase the rate of this chemical reaction?

- 1 increasing the concentration of sulfuric acid
- 2 increasing the size of the pieces of copper(II) carbonate
- 3 increasing the temperature
- 4 increasing the volume of sulfuric acid

**A** 1, 3 and 4      **B** 1 and 3 only      **C** 2 and 3      **D** 3 and 4 only

14 In which reaction is the first substance in the equation oxidised?

- A**  $\text{CaO} + \text{H}_2\text{O} \rightarrow \text{Ca}(\text{OH})_2$
- B**  $4\text{FeO} + \text{O}_2 \rightarrow 2\text{Fe}_2\text{O}_3$
- C**  $\text{SnO}_2 + 2\text{H}_2 \rightarrow \text{Sn} + 2\text{H}_2\text{O}$
- D**  $\text{ZnCO}_3 \rightarrow \text{ZnO} + \text{CO}_2$

15 The equation for the effect of heat on hydrated sodium carbonate is as shown.

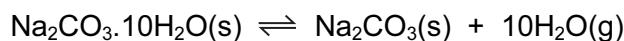

Statements made by four students about the reaction are given.

- P** Anhydrous sodium carbonate is formed.
- Q** Steam is formed.
- R** There is a colour change from blue to white.
- S** The reaction is reversible.

Which students' statements are correct?

- A** P, Q and R only
- B** P, Q and S only
- C** Q, R and S only
- D** P, Q, R and S

16 Which reaction is a neutralisation reaction?

- A  $\text{AgNO}_3 + \text{HCl} \rightarrow \text{AgCl} + \text{HNO}_3$
- B  $\text{CaCO}_3 \rightarrow \text{CaO} + \text{CO}_2$
- C  $4\text{Na} + \text{O}_2 \rightarrow 2\text{Na}_2\text{O}$
- D  $2\text{NaOH} + \text{H}_2\text{SO}_4 \rightarrow \text{Na}_2\text{SO}_4 + 2\text{H}_2\text{O}$

17 Elements W and X are metals.

Elements Y and Z are non-metals.

The oxides of W, X, Y and Z all form solutions when added to water.

Which statement is correct?

- A The solution of the oxide of element W turns blue litmus red.
- B The solution of the oxide of element X fizzes when sodium carbonate is added.
- C The solution of the oxide of element Y has a pH greater than pH 7.
- D The solution of the oxide of element Z fizzes when powdered magnesium is added.

18 A student is given an unknown solution.

Which two tests provide evidence that the solution is copper(II) sulfate?

- 1 adding dilute hydrochloric acid
- 2 adding aqueous sodium hydroxide
- 3 adding dilute nitric acid, then silver nitrate solution
- 4 adding dilute nitric acid, then barium nitrate solution

- A 1 and 3      B 1 and 4      C 2 and 3      D 2 and 4

19 The diagram shows the steps in the preparation of a salt.

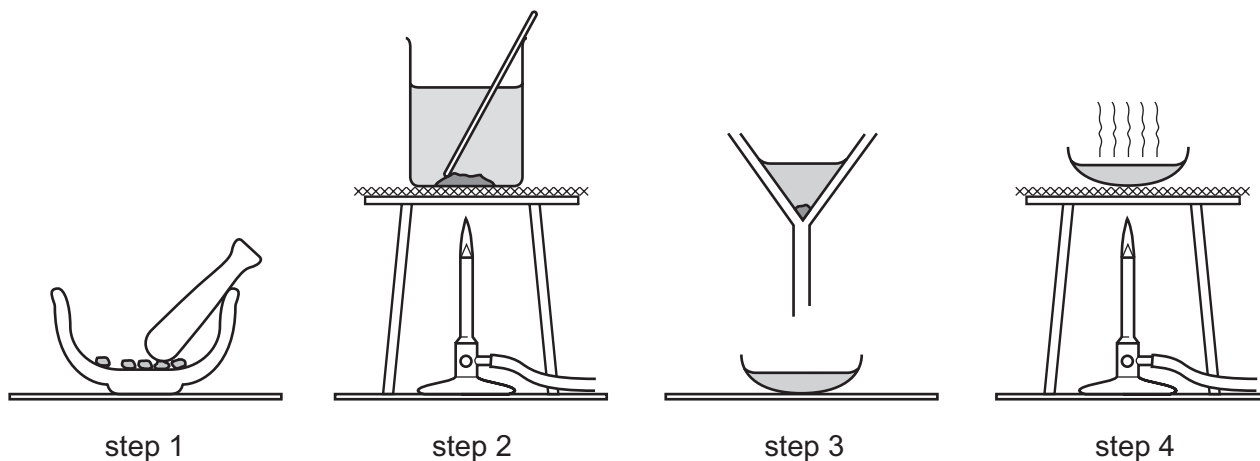

Which salt is prepared by this method?

- A barium sulfate
  - B copper(II) sulfate
  - C potassium sulfate
  - D sodium sulfate
- 20 Which property of elements increases across a period of the Periodic Table?
- A metallic character
  - B number of electron shells
  - C number of outer shell electrons
  - D tendency to form positive ions
- 21 The noble gases are in Group VIII of the Periodic Table.
- Which statement explains why noble gases are unreactive?
- A They all have eight electrons in their outer shells.
  - B They all have full outer shells.
  - C They are all gases.
  - D They are all monoatomic.
- 22 Which compound is made from elements which are **all** in the same period?
- A  $Al_2(SO_4)_3$
  - B  $C_2H_5OH$
  - C  $LiNO_3$
  - D  $Na_3AlF_6$



26 Which metal is commonly used to form alloys with a non-metallic element?

- A copper
- B iron
- C magnesium
- D zinc

27 Steel is made by adding ..... 1 ..... to molten iron to remove ..... 2 ..... from the iron.

Stainless steel is ..... 3 ..... resistant to corrosion than mild steel.

Which words complete the gaps 1, 2 and 3?

	1	2	3
<b>A</b>	basic oxides	acidic impurities	less
<b>B</b>	basic oxides	carbon	more
<b>C</b>	oxygen	acidic impurities	less
<b>D</b>	oxygen	carbon	more

28 Water is added to hydrated copper(II) sulfate.

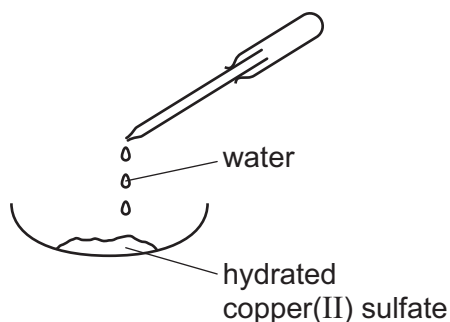

Which colour change takes place?

- A blue to pink
- B blue to white
- C no change
- D white to blue

29 Two reactions, X and Y, produce carbon dioxide.

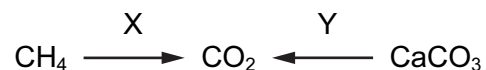

Which types of reaction are X and Y?

	X	Y
<b>A</b>	combustion	combustion
<b>B</b>	combustion	thermal decomposition
<b>C</b>	thermal decomposition	combustion
<b>D</b>	thermal decomposition	thermal decomposition

30 An experiment to find the percentage of oxygen in  $150 \text{ cm}^3$  of polluted air is shown.

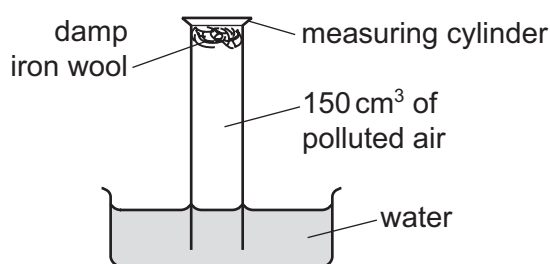

The apparatus is left for one week.

After this time, the volume of gas in the measuring cylinder is  $122 \text{ cm}^3$ .

What is the percentage of oxygen, to the nearest whole number, in the polluted air?

- A** 19%      **B** 21%      **C** 28%      **D** 81%

31 Ammonia is produced when a mixture of ammonium chloride and substance X is heated.

What is substance X?

- A** ammonium sulfate  
**B** barium chloride  
**C** calcium hydroxide  
**D** silver nitrate

32 Which row is correct for both carbon dioxide and methane?

	causes climate change	produced by burning fuels	produced by living organisms
<b>A</b>	✓	✓	✓
<b>B</b>	✓	✓	x
<b>C</b>	✓	x	✓
<b>D</b>	x	✓	✓

33 Which statements about sulfur dioxide are correct?

- 1 It dissolves in water to produce a solution with a pH less than pH 7.
- 2 It is used as a food preservative.
- 3 It changes potassium manganate(VII) from colourless to purple.
- 4 It is produced by the combustion of sulfur-containing fossil fuels.

**A** 1, 2 and 3      **B** 1, 2 and 4      **C** 1, 3 and 4      **D** 2, 3 and 4

34 A student carried out two experiments.

experiment 1 The student heated a sample of limestone very strongly. A white powder formed.

experiment 2 The white powder from experiment 1 was cooled. The student then added a small quantity of cold water to the powder. Large quantities of steam were produced.

Which statement is **not** correct?

- A** An endothermic reaction occurred in experiment 1.
- B** An exothermic reaction occurred in experiment 2.
- C** Thermal decomposition occurred in experiment 1.
- D** Thermal decomposition occurred in experiment 2.

35 Which substance has a main constituent that contains **only one** carbon atom per molecule?

- A** bitumen
- B** gasoline
- C** natural gas
- D** petroleum

36 The table shows the composition of four different types of petroleum.

fraction	Arabian Heavy /%	Arabian Light /%	Iranian Heavy /%	North Sea /%
gasoline	18	21	21	23
kerosene	11	15	13	15
diesel oil	18	21	20	24
fuel oil	53	43	46	38

Which type of petroleum is best for the motor vehicle industry?

- A Arabian Heavy
- B Arabian Light
- C Iranian Heavy
- D North Sea

37 Ethanol is a fuel used in cars. It can be made from petroleum.

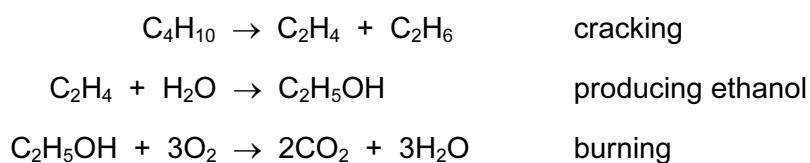

Compounds of how many homologous series appear in these equations?

- A 1                      B 2                      C 3                      D 4

38 Ethanol is produced from either ethene or sugar.

Which type of chemical reaction is used in each case?

	ethene → ethanol	sugar → ethanol
A	addition	fermentation
B	addition	fractional distillation
C	distillation	fermentation
D	distillation	fractional distillation

- 39 Which type of hydrocarbon reacts rapidly with aqueous bromine and what is the colour change of the aqueous bromine?

	type of hydrocarbon	colour change of the aqueous bromine
<b>A</b>	alkane	brown to colourless
<b>B</b>	alkane	colourless to brown
<b>C</b>	alkene	brown to colourless
<b>D</b>	alkene	colourless to brown

- 40 The diagram shows the structure of an important product.

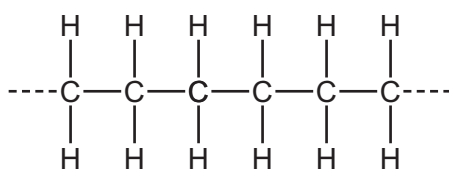

This product is formed by ..... 1 ..... of an ..... 2 .....

Which words complete gaps 1 and 2?

	1	2
<b>A</b>	addition polymerisation	alkane
<b>B</b>	addition polymerisation	alkene
<b>C</b>	cracking	alkane
<b>D</b>	cracking	alkene

Permission to reproduce items where third-party owned material protected by copyright is included has been sought and cleared where possible. Every reasonable effort has been made by the publisher (UCLES) to trace copyright holders, but if any items requiring clearance have unwittingly been included, the publisher will be pleased to make amends at the earliest possible opportunity.

To avoid the issue of disclosure of answer-related information to candidates, all copyright acknowledgements are reproduced online in the Cambridge International Examinations Copyright Acknowledgements Booklet. This is produced for each series of examinations and is freely available to download at [www.cie.org.uk](http://www.cie.org.uk) after the live examination series.

Cambridge International Examinations is part of the Cambridge Assessment Group. Cambridge Assessment is the brand name of University of Cambridge Local Examinations Syndicate (UCLES), which is itself a department of the University of Cambridge.

The Periodic Table of Elements

Group																															
I	II	III						IV	V	VI	VII	VIII																			
3 <b>Li</b> lithium 7	4 <b>Be</b> beryllium 9	<div style="border: 1px solid black; padding: 5px; text-align: center;"> <b>Key</b>                      atomic number                      atomic symbol                      name                      relative atomic mass                 </div>										2 <b>He</b> helium 4																			
11 <b>Na</b> sodium 23	12 <b>Mg</b> magnesium 24											5 <b>B</b> boron 11	6 <b>C</b> carbon 12	7 <b>N</b> nitrogen 14	8 <b>O</b> oxygen 16	9 <b>F</b> fluorine 19	10 <b>Ne</b> neon 20														
19 <b>K</b> potassium 39	20 <b>Ca</b> calcium 40	13 <b>Al</b> aluminium 27	14 <b>Si</b> silicon 28	15 <b>P</b> phosphorus 31	16 <b>S</b> sulfur 32	17 <b>Cl</b> chlorine 35.5	18 <b>Ar</b> argon 40	37 <b>Rb</b> rubidium 85	38 <b>Sr</b> strontium 88	39 <b>Y</b> yttrium 89	40 <b>Zr</b> zirconium 91	41 <b>Nb</b> niobium 93	42 <b>Mo</b> molybdenum 96	43 <b>Tc</b> technetium —	44 <b>Ru</b> ruthenium 101	45 <b>Rh</b> rhodium 103	46 <b>Pd</b> palladium 106	47 <b>Ag</b> silver 108	48 <b>Cd</b> cadmium 112	49 <b>In</b> indium 115	50 <b>Sn</b> tin 119	51 <b>Sb</b> antimony 122	52 <b>Te</b> tellurium 128	53 <b>I</b> iodine 127	54 <b>Xe</b> xenon 131						
55 <b>Cs</b> caesium 133	56 <b>Ba</b> barium 137	57–71 lanthanoids	72 <b>Hf</b> hafnium 178	73 <b>Ta</b> tantalum 181	74 <b>W</b> tungsten 184	75 <b>Re</b> rhenium 186	76 <b>Os</b> osmium 190	77 <b>Ir</b> iridium 192	78 <b>Pt</b> platinum 195	79 <b>Au</b> gold 197	80 <b>Hg</b> mercury 201	81 <b>Tl</b> thallium 204	82 <b>Pb</b> lead 207	83 <b>Bi</b> bismuth 209	84 <b>Po</b> polonium —	85 <b>At</b> astatine —	86 <b>Rn</b> radon —	87 <b>Fr</b> francium —	88 <b>Ra</b> radium —	89–103 actinoids	104 <b>Rf</b> rutherfordium —	105 <b>Db</b> dubnium —	106 <b>Sg</b> seaborgium —	107 <b>Bh</b> bohrium —	108 <b>Hs</b> hassium —	109 <b>Mt</b> meitnerium —	110 <b>Ds</b> darmstadtium —	111 <b>Rg</b> roentgenium —	112 <b>Cn</b> copernicium —	114 <b>Fl</b> flerovium —	116 <b>Lv</b> livermorium —

57 <b>La</b> lanthanum 139	58 <b>Ce</b> cerium 140	59 <b>Pr</b> praseodymium 141	60 <b>Nd</b> neodymium 144	61 <b>Pm</b> promethium —	62 <b>Sm</b> samarium 150	63 <b>Eu</b> europium 152	64 <b>Gd</b> gadolinium 157	65 <b>Tb</b> terbium 159	66 <b>Dy</b> dysprosium 163	67 <b>Ho</b> holmium 165	68 <b>Er</b> erbium 167	69 <b>Tm</b> thulium 169	70 <b>Yb</b> ytterbium 173	71 <b>Lu</b> lutetium 175
89 <b>Ac</b> actinium —	90 <b>Th</b> thorium 232	91 <b>Pa</b> protactinium 231	92 <b>U</b> uranium 238	93 <b>Np</b> neptunium —	94 <b>Pu</b> plutonium —	95 <b>Am</b> americium —	96 <b>Cm</b> curium —	97 <b>Bk</b> berkelium —	98 <b>Cf</b> californium —	99 <b>Es</b> einsteinium —	100 <b>Fm</b> fermium —	101 <b>Md</b> mendelevium —	102 <b>No</b> nobelium —	103 <b>Lr</b> lawrencium —

lanthanoids

actinoids

The volume of one mole of any gas is 24 dm<sup>3</sup> at room temperature and pressure (r.t.p.).