



Cambridge IGCSE™

CHEMISTRY

0620/22

Paper 2 Multiple Choice (Extended)

May/June 2022

45 minutes

You must answer on the multiple choice answer sheet.

You will need: Multiple choice answer sheet
Soft clean eraser
Soft pencil (type B or HB is recommended)

INSTRUCTIONS

- There are **forty** questions on this paper. Answer **all** questions.
- For each question there are four possible answers **A, B, C** and **D**. Choose the **one** you consider correct and record your choice in soft pencil on the multiple choice answer sheet.
- Follow the instructions on the multiple choice answer sheet.
- Write in soft pencil.
- Write your name, centre number and candidate number on the multiple choice answer sheet in the spaces provided unless this has been done for you.
- Do **not** use correction fluid.
- Do **not** write on any bar codes.
- You may use a calculator.

INFORMATION

- The total mark for this paper is 40.
- Each correct answer will score one mark.
- Any rough working should be done on this question paper.
- The Periodic Table is printed in the question paper.

This document has **16** pages.



- 1 Which two gases will diffuse at the same rate, at the same temperature?
- A** carbon monoxide and carbon dioxide
B carbon monoxide and nitrogen
C chlorine and fluorine
D nitrogen and oxygen
- 2 A student measures the time taken for 2.0g of magnesium to dissolve in 50 cm³ of dilute sulfuric acid.

Which apparatus is essential to complete the experiment?

- 1 stop-clock
 2 measuring cylinder
 3 thermometer
 4 balance

- A** 1, 2 and 4 **B** 1 and 2 only **C** 1 and 4 only **D** 2, 3 and 4

- 3 A chromatogram of a single substance T is shown.

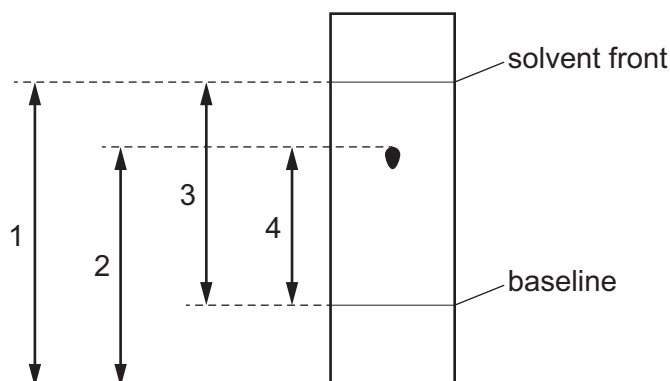

Which measurements are used to find the R_f value of T?

- A** 1 and 2 **B** 1 and 4 **C** 2 and 3 **D** 3 and 4

- 4 X and Y are two different elements.

X and Y have the same number of nucleons.

Which statement about X and Y is correct?

- A** They have the same physical properties.
B Their atoms have the same number of electrons.
C They are in different groups of the Periodic Table.
D They have different relative masses.

5 The diagrams show the structures of three macromolecules P, Q and R.

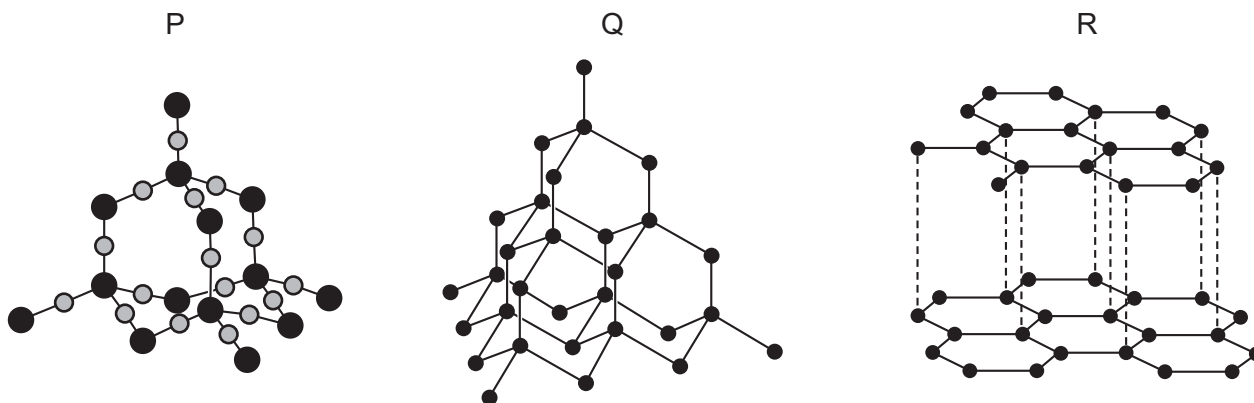

What are P, Q and R?

	P	Q	R
A	diamond	silicon(IV) oxide	graphite
B	graphite	diamond	silicon(IV) oxide
C	silicon(IV) oxide	diamond	graphite
D	silicon(IV) oxide	graphite	diamond

6 Which dot-and-cross diagram shows the arrangement of outer shell electrons in a molecule of hydrogen chloride?

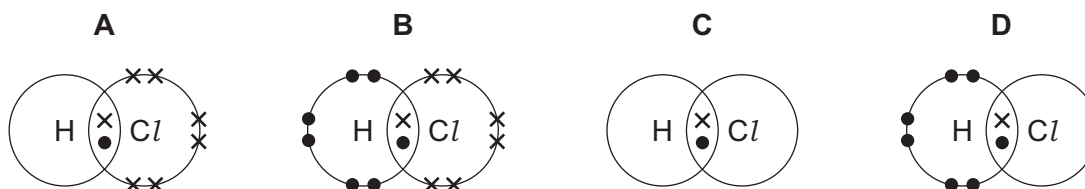

7 The equation for the reaction between barium chloride and dilute sulfuric acid is shown.

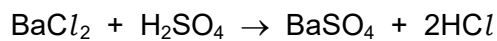

Which row shows the state symbols for this equation?

	BaCl_2	H_2SO_4	BaSO_4	2HCl
A	(aq)	(aq)	(s)	(aq)
B	(aq)	(l)	(s)	(aq)
C	(l)	(aq)	(s)	(l)
D	(aq)	(l)	(aq)	(l)

- 8 Methane and steam react in the presence of a catalyst.

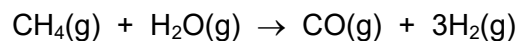

0.5 mol of methane reacts completely with 0.5 mol of steam.

What is the volume of carbon monoxide and hydrogen produced, measured at room temperature and pressure?

	volume of CO/dm ³	volume of H ₂ /dm ³
A	0.5	1.5
B	1.0	3.0
C	12.0	12.0
D	12.0	36.0

- 9 A compound of element X has the formula X₂O and a relative formula mass of 144.

What is element X?

- A** copper, Cu
- B** gadolinium, Gd
- C** sulfur, S
- D** tellurium, Te

- 10 The diagram shows the electrolysis of concentrated hydrochloric acid and concentrated aqueous sodium chloride using carbon electrodes.

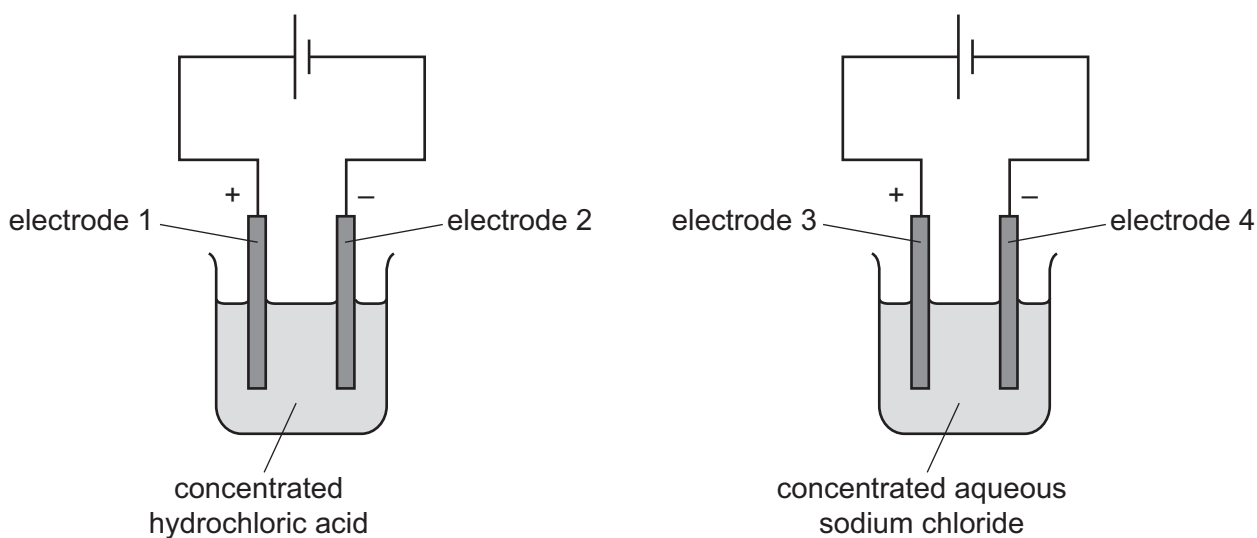

At which electrodes is hydrogen produced?

- A electrode 1 only
 - B electrodes 1 and 3
 - C electrode 2 only
 - D electrodes 2 and 4
- 11 The diagram shows the electrolysis of aqueous copper(II) sulfate using inert electrodes.

Which arrow shows the movement of electrons in the circuit?

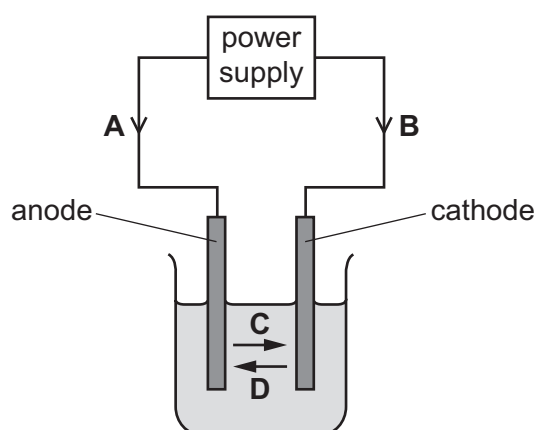

12 Which row identifies a chemical change and a physical change?

	chemical change	physical change
A	boiling ethanol	burning ethanol
B	burning ethanol	evaporating ethanol
C	dissolving ethanol in water	burning ethanol
D	evaporating ethanol	dissolving ethanol in water

13 Which statements explain why increasing the concentration of a reactant increases the rate of reaction?

- 1 It increases the collision rate of particles.
- 2 It lowers the activation energy.
- 3 A greater proportion of the colliding molecules have the required activation energy.
- 4 There are more particles per unit volume.

A 1 and 3 **B** 1 and 4 **C** 2 and 3 **D** 2 and 4

14 When the colourless gas N_2O_4 is heated, it forms the brown gas NO_2 .

When the reaction mixture is cooled, the brown colour fades and turns back to colourless.

Which type of reaction is described by these observations?

- A** decomposition
- B** displacement
- C** reduction
- D** reversible

15 Water is added to anhydrous copper(II) sulfate.

What happens during the reaction?

- A** The copper(II) sulfate turns blue and the solution formed gets colder.
- B** The copper(II) sulfate turns blue and the solution formed gets hotter.
- C** The copper(II) sulfate turns white and the solution formed gets colder.
- D** The copper(II) sulfate turns white and the solution formed gets hotter.

- 16 Which arrow on the energy level diagram shows the overall energy change for an endothermic reaction?

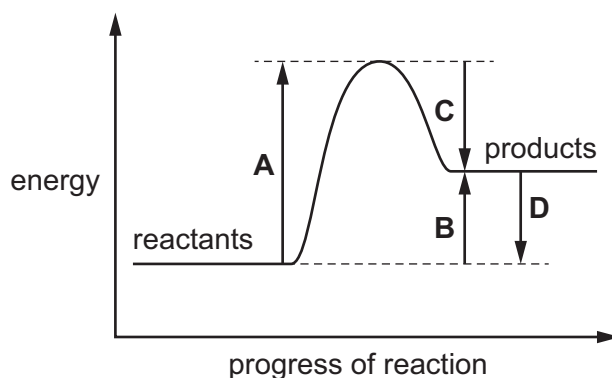

- 17 When a hydrogen–oxygen fuel cell is in operation, a different reaction happens at each electrode.

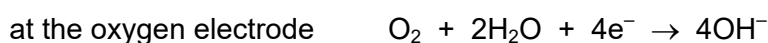

The electrons that are lost at the hydrogen electrode travel through the external circuit to the oxygen electrode, where they are gained by the oxygen and water.

A hydrogen–oxygen fuel cell is operated for a period of time and four moles of oxygen molecules are consumed.

Which mass of hydrogen is consumed?

- A** 2.0g **B** 4.0g **C** 8.0g **D** 16.0g

- 18 The oxides of two elements, X and Y, are separately dissolved in water and the pH of each solution tested.

oxide tested	pH of solution
X	1
Y	13

Which information about X and Y is correct?

	oxide is acidic	oxide is basic	metal	non-metal
A	X	Y	X	Y
B	X	Y	Y	X
C	Y	X	X	Y
D	Y	X	Y	X

19 An acid is neutralised by adding an excess of an insoluble solid base.

A soluble salt is formed.

How is the pure salt obtained from the reaction mixture?

- A crystallisation → evaporation → filtration
- B evaporation → crystallisation → filtration
- C filtration → crystallisation → evaporation
- D filtration → evaporation → crystallisation

20 Substance J takes part in a redox reaction.

In the reaction, J gains electrons.

Which statement is correct?

- A J is the oxidising agent and it is oxidised in the reaction.
- B J is the oxidising agent and it is reduced in the reaction.
- C J is the reducing agent and it is oxidised in the reaction.
- D J is the reducing agent and it is reduced in the reaction.

21 Elements in Group IV of the Periodic Table are shown.

carbon

silicon

germanium

tin

lead

What does **not** occur in Group IV as it is descended?

- A The proton number of the elements increases.
- B The elements become more metallic.
- C The elements have more electrons in their outer shell.
- D The elements have more electron shells.

22 Which statement about acids is correct?

- A Acids are proton acceptors.
- B Acids transfer electrons to bases in aqueous solution.
- C Hydrochloric acid reacts with ammonium hydroxide to produce ammonia.
- D Ethanoic acid partially ionises in aqueous solution.

23 Which elements have both a high melting point and variable oxidation states?

- A alkali metals
- B transition elements
- C halogens
- D noble gases

24 Lithium, sodium and potassium are elements in Group I of the Periodic Table.

Chlorine, bromine and iodine are elements in Group VII of the Periodic Table.

Which row identifies the **least** dense of these elements in each group?

	Group I	Group VII
A	lithium	chlorine
B	lithium	iodine
C	potassium	chlorine
D	potassium	iodine

25 The reactions of metals P, Q, R and S are shown.

metal	reaction with water	reaction with hydrochloric acid	reduction of the metal oxide with carbon
P	no reaction	no reaction	reduced
Q	slow	vigorous	no reaction
R	vigorous	vigorous	no reaction
S	very slow	vigorous	reduced

What is the order of reactivity of the metals?

	least reactive \longrightarrow most reactive			
A	P	S	Q	R
B	P	Q	S	R
C	R	S	Q	P
D	R	Q	S	P

26 The number of protons and the number of neutrons in the atoms of elements X, Y and Z are shown.

	number of protons	number of neutrons
X	6	6
Y	7	6
Z	8	10

Which statement about the elements is correct?

- A** X and Y are isotopes of the same element.
- B** Z forms an ion with a +2 charge.
- C** X and Z react together to form an ionic compound.
- D** X, Y and Z are non-metals.

27 Which diagram represents the arrangement of atoms in an alloy?

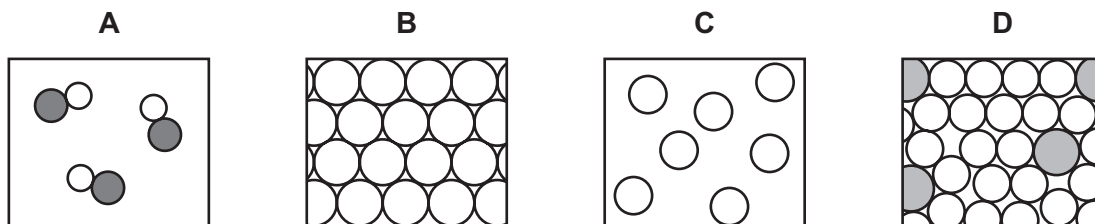

28 Three metal compounds, J, K and L, are heated using a Bunsen burner.

The results are shown.

J colourless gas produced, which relights a glowing splint

K colourless gas produced, which turns limewater milky

L no reaction

Which row identifies J, K and L?

	J	K	L
A	magnesium carbonate	potassium carbonate	potassium nitrate
B	magnesium carbonate	potassium nitrate	potassium carbonate
C	potassium nitrate	magnesium carbonate	potassium carbonate
D	potassium nitrate	potassium carbonate	magnesium carbonate

29 Processes involved in the extraction of zinc are listed.

1 Heat zinc oxide with carbon.

2 Condense zinc vapour.

3 Vaporise the zinc.

4 Roast zinc ore in air.

In which order are the processes carried out?

A 1 → 2 → 3 → 4

B 4 → 3 → 1 → 2

C 4 → 1 → 3 → 2

D 1 → 4 → 3 → 2

30 Which process uses sacrificial protection to prevent steel from rusting?

- A galvanising
- B oiling
- C copper plating
- D painting

31 Fertilisers are used to provide three of the elements needed for plant growth.

Which two compounds would give a fertiliser containing all three of these elements?

- A $\text{Ca}(\text{NO}_3)_2$ and $(\text{NH}_4)_2\text{SO}_4$
- B $\text{Ca}(\text{NO}_3)_2$ and $(\text{NH}_4)_3\text{PO}_4$
- C KNO_3 and $(\text{NH}_4)_2\text{SO}_4$
- D KNO_3 and $(\text{NH}_4)_3\text{PO}_4$

32 Which processes produce carbon dioxide?

- 1 respiration
- 2 photosynthesis
- 3 fermentation
- 4 combustion of hydrogen

- A 1 and 3 B 1 and 4 C 2 and 3 D 2 and 4

33 Which reaction in the Contact process requires the use of a catalyst?

- A $\text{S} + \text{O}_2 \rightarrow \text{SO}_2$
- B $2\text{SO}_2 + \text{O}_2 \rightarrow 2\text{SO}_3$
- C $\text{SO}_3 + \text{H}_2\text{SO}_4 \rightarrow \text{H}_2\text{S}_2\text{O}_7$
- D $\text{H}_2\text{S}_2\text{O}_7 + \text{H}_2\text{O} \rightarrow 2\text{H}_2\text{SO}_4$

34 What are the products when limestone (calcium carbonate) is heated strongly?

- A calcium hydroxide and carbon dioxide
- B calcium hydroxide and carbon monoxide
- C calcium oxide and carbon dioxide
- D calcium oxide and carbon monoxide

35 The structure of ester W is shown.

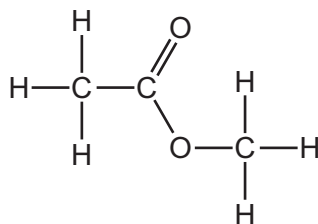

Which row gives the names of ester W and the carboxylic acid and alcohol from which it is made?

	name of ester W	carboxylic acid	alcohol
A	ethyl methanoate	ethanoic acid	methanol
B	ethyl methanoate	methanoic acid	ethanol
C	methyl ethanoate	ethanoic acid	methanol
D	methyl ethanoate	methanoic acid	ethanol

36 Ethene reacts with substance X to form ethanol.

What is X?

- A** ethanoic acid
- B** glucose
- C** hydrogen
- D** steam

37 Alkenes can be produced by cracking large hydrocarbon molecules to form smaller hydrocarbon molecules.

Which equations represent possible reactions when tetradecane, $C_{14}H_{30}$, is cracked?

- 1 $C_{14}H_{30} \rightarrow C_2H_6 + C_3H_6 + C_4H_8 + C_5H_{10}$
- 2 $C_{14}H_{30} \rightarrow H_2 + C_2H_4 + C_3H_6 + C_4H_8 + C_5H_{10}$
- 3 $C_{14}H_{30} \rightarrow C_2H_6 + 4C_3H_6$
- 4 $C_{14}H_{30} \rightarrow C_2H_6 + C_3H_8 + C_9H_{18}$

- A** 1 only **B** 1 and 4 **C** 1, 2 and 3 **D** 3 and 4

40 Which polymer structure has the same linkages as *Terylene*?

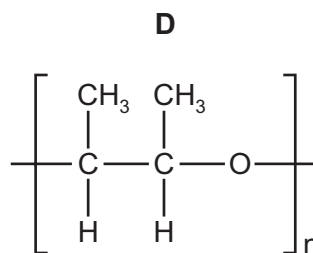
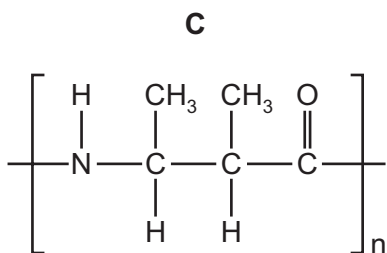
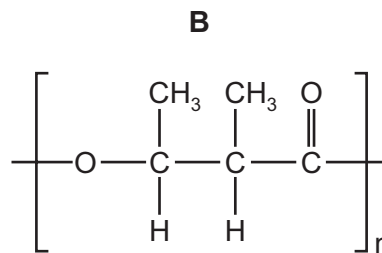
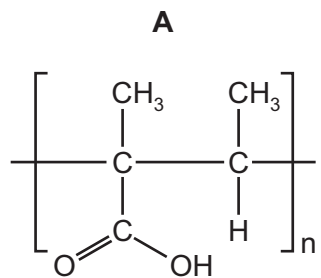

Permission to reproduce items where third-party owned material protected by copyright is included has been sought and cleared where possible. Every reasonable effort has been made by the publisher (UCLES) to trace copyright holders, but if any items requiring clearance have unwittingly been included, the publisher will be pleased to make amends at the earliest possible opportunity.

To avoid the issue of disclosure of answer-related information to candidates, all copyright acknowledgements are reproduced online in the Cambridge Assessment International Education Copyright Acknowledgements Booklet. This is produced for each series of examinations and is freely available to download at www.cambridgeinternational.org after the live examination series.

Cambridge Assessment International Education is part of Cambridge Assessment. Cambridge Assessment is the brand name of the University of Cambridge Local Examinations Syndicate (UCLES), which is a department of the University of Cambridge.

The Periodic Table of Elements

Group															
I	II	III						IV	V	VI	VII	VIII			
3 Li lithium 7	4 Be beryllium 9	<div style="border: 1px solid black; padding: 5px; text-align: center;"> Key atomic number atomic symbol name relative atomic mass </div>										2 He helium 4			
11 Na sodium 23	12 Mg magnesium 24											5 B boron 11	6 C carbon 12	7 N nitrogen 14	8 O oxygen 16
19 K potassium 39	20 Ca calcium 40	13 Al aluminium 27	14 Si silicon 28	15 P phosphorus 31	16 S sulfur 32	17 Cl chlorine 35.5	18 Ar argon 40	33 As arsenic 75	34 Se selenium 79	35 Br bromine 80	36 Kr krypton 84				
37 Rb rubidium 85	38 Sr strontium 88	39 Y yttrium 89	40 Zr zirconium 91	41 Nb niobium 93	42 Mo molybdenum 96	43 Tc technetium —	44 Ru ruthenium 101	45 Rh rhodium 103	46 Pd palladium 106	47 Ag silver 108	48 Cd cadmium 112	51 Sb antimony 122	52 Te tellurium 128	53 I iodine 127	54 Xe xenon 131
55 Cs caesium 133	56 Ba barium 137	57–71 lanthanoids	72 Hf hafnium 178	73 Ta tantalum 181	74 W tungsten 184	75 Re rhenium 186	76 Os osmium 190	77 Ir iridium 192	78 Pt platinum 195	79 Au gold 197	80 Hg mercury 201	83 Bi bismuth 209	84 Po polonium —	85 At astatine —	86 Rn radon —
87 Fr francium —	88 Ra radium —	89–103 actinoids	104 Rf rutherfordium —	105 Db dubnium —	106 Sg seaborgium —	107 Bh bohrium —	108 Hs hassium —	109 Mt meitnerium —	110 Ds darmstadtium —	111 Rg roentgenium —	112 Cn copernicium —	116 Lv livermorium —	—	—	—

lanthanoids	57 La lanthanum 139	58 Ce cerium 140	59 Pr praseodymium 141	60 Nd neodymium 144	61 Pm promethium —	62 Sm samarium 150	63 Eu europium 152	64 Gd gadolinium 157	65 Tb terbium 159	66 Dy dysprosium 163	67 Ho holmium 165	68 Er erbium 167	69 Tm thulium 169	70 Yb ytterbium 173	71 Lu lutetium 175
actinoids	89 Ac actinium —	90 Th thorium 232	91 Pa protactinium 231	92 U uranium 238	93 Np neptunium —	94 Pu plutonium —	95 Am americium —	96 Cm curium —	97 Bk berkelium —	98 Cf californium —	99 Es einsteinium —	100 Fm fermium —	101 Md mendelevium —	102 No nobelium —	103 Lr lawrencium —

The volume of one mole of any gas is 24 dm³ at room temperature and pressure (r.t.p.).